



**MODEL: RCT-MLT IV**

**INSTALLATION AND OPERATION INSTRUCTIONS**

**IF YOU CANNOT READ OR UNDERSTAND THESE INSTALLATION INSTRUCTIONS DO NOT ATTEMPT TO INSTALL OR OPERATE**

**INTRODUCTION**

This remote control system was developed to provide safe, reliable, user-friendly remote control system for gas appliances. It is a dry contact thermostat system that can manually operate fan speed and flame height from the transmitter.

**TRANSMITTER**

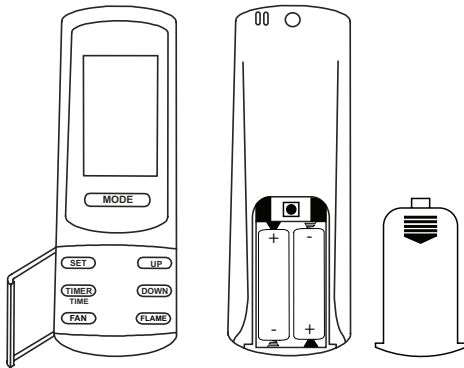

The transmitter operates on (2) AAA 1.5V batteries that are included. Install the AAA batteries supplied with the unit into the battery compartment. It is recommended that ALKALINE batteries always be used for this product. **Be sure the batteries are installed with the (+) and (-) ends facing the correct direction.**

If the transmitter does not illuminate when you press any buttons, or you see nothing on the LCD screen, check the position of the batteries.

**LIQUID CRYSTAL DISPLAY - LCD**

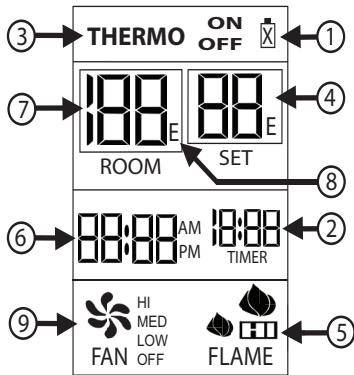

1. **Low Battery Indicator** - Battery power is low, replace batteries within two weeks.
2. **Timer** - Time remaining before the system shuts off, must be programmed.
3. **Mode** - Indicates whether the system is ON, OFF, or in THERMO mode.
4. **Set** - Indicates the desired SET temperature when in THERMO mode.
5. **Flame** - Indicates burner/valve operational.
6. **Clock** - Indicates current time.
7. **Room** - Indicates current ROOM temperature.
8. **°F** - Indicates degrees Fahrenheit (°C indicates degrees Celsius).
9. **Fan** - Indicates the fan is ON, or is programmed to come ON.

**MODE FUNCTION**

To select an operational mode, press the MODE button on the transmitter.

**ON** - Turns the appliance ON, the flame icon will appear on the LCD screen.

**THERMO** - Remote is in THERMO mode.

**OFF** - Turns the appliance OFF, the flame will disappear from the LCD screen.

**SETTING °FAHRENHEIT / °CELSIUS SCALE**

The factory setting for temperature is degrees fahrenheit (°F). To change this setting to degrees Centigrade (°C):

- Remove battery cover on the back of the transmitter and locate the setting button in the top center of the battery compartment.
- Push the button once to enter temperature scale setting mode.
- Use the up and down buttons to switch between the °F and °C.
- Push the setting button again once again to set the displayed temperature scale.
- Repeat this procedure to switch back to °F.

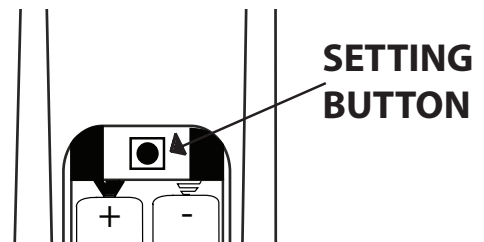

## THERMOSTAT FUNCTION

- Press the **MODE** key until the LCD screen shows the word "THERMO" at the top of the screen.
- To adjust set temperature, press the **UP** and **DOWN** buttons until the desired temperature is reached. The temperature range is 99°F (32°C) to 45°F (6°C).
- If no button is pressed, the set temperature will automatically be accepted.
- The flame icon will appear when the control calls for heat. The flame icon will disappear when the appliance reaches its set temperature.
- Press the **MODE** key to disengage the Thermo Mode.

## SETTING THE TEMPERATURE SWING (TEMPERATURE DIFFERENTIAL)

The Thermo Mode on the transmitter operates the appliance whenever the room temperature varies a certain number of degrees from the set temperature. This variation is called the "**SWING**" or **TEMPERATURE DIFFERENTIAL**. The factory preset swing temperature is 2 °F (1 °C). To change the "Swing Setting:"

## OPERATING THE FAN

This remote control system has the capability of operating a 110 VAC fan or blower system that may be included with you gas fireplace. The fan will only operate when the transmitter in the ON or THERMO modes (THERMO or ON must be displayed on the LCD Screen).

- To turn on the fan, press the **FAN** button on your transmitter.
- You can switch through the various positions by pressing the fan until the desired speed is obtained.
- Your speed options are High, Medium, Low, and Off.

## SETTING THE COUNTDOWN TIMER

This remote control system can operate with a built-in countdown timer when the transmitter is in the ON or THERMO modes (THERMO or ON must be displayed on the screen).

- Press and release the **TIMER** button. The minimum 0:15 minute setting on the will begin to flash.
- Press the **UP** or **DOWN** button on the transmitter to chose your countdown time. Available countdown times are 15 min, 30 min, 45 min, 1 hour to 9 hours (alternating every 30 min).
- To initiate the countdown, simply press the **SET** button or wait 15 seconds for it to stop flashing. The appliance will turn off when the timer runs out.

## RECEIVER

The remote receiver os powered by 110-120VAC. It plugs into a standard polarized duplex receptacle. The remote receiver has a 3-position slide switch for selecting the mode of operation **ON/REMOTE/OFF**

- **ON**: will manually turn on the appliance.
- **REMOTE**: will allow use of handheld transmitter. If the system does not respond to the transmitter on initial use, check the battery positions in the remote. If that does not work, see the LEARNING TRANSMITTER TO RECEIVER section.
- **OFF**: will disable the remote receiver.

**Note:** This product is designed for use with an attended hearth appliance or fire feature. Adults must be present when the Control System is operating. **DO NOT** program or thermostatically set this Control to operate a hearth appliance or fire feature when Adults are not physically present. Furthermore, **DO NOT** leave the hearth appliance or fire feature burning unattended; it may cause damage or serious injury. If an Adult is going to be away from the hearth appliance or fire feature for any length of time, then the handheld/wall mount, receiver/control module and application should be in the "OFF" position.

## FLAME HEIGHT

This remote control system allows the user to control the height of the flame when the gas valve is factory equipped with a flame controller.

- Press and release the flame button to change the flame from regular to HI.
- When the flame is switched to HI, the word HI in a black box and a second flame appears in the lower right hand corner of the LCD screen. When switched back to regular flame, they both disappear.

## SETTING THE CLOCK

- Hold the TIMER/TIME button for 3 seconds. The hour section of the time should begin flashing.
- Select the hour by pressing the UP and DOWN buttons. If you go past 12 o'clock the AM and PM will change.
- Once the hour is selected, press and release the TIMER/TIME button again, and the minute section of the time should be flashing.
- Use the UP and DOWN buttons to scroll through the minutes.
- Once the minutes are correct, press and hold the TIMER/TIME button for 3 seconds. The time is now set.

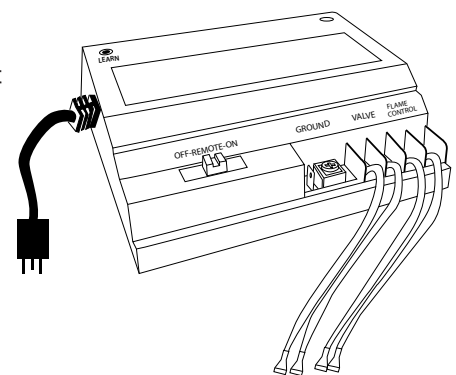

## WARNING

This remote control system must be installed exactly as outlined in these instructions. Read all instructions completely before attempting installation. Follow instructions carefully during installation. Any modifications of this remote control or any of its components will void the warranty and may pose a fire hazard.

Do not connect any gas valve or electronic module directly to 110-120VAC power. Consult gas appliance manufacturer's instructions and wiring schematics for proper placement of all wires. All electronic modules are to be wired to manufacturer's specifications.

The following wiring diagrams are for illustration purpose only. Follow instructions from manufacturer of gas valve and/or electronic module for correct wiring procedures. Improper installation of electric components can cause damage to electronic module, gas valve and remote receiver.

## INSTALLATION

Before installation make sure the remote receiver slide switch is in the **OFF** position. After installation be sure that the slide switch is moved to the **REMOTE** position.

### MOUNTING THE REMOTE RECEIVER

#### HEARTH MOUNT

- The remote receiver can be placed on the fireplace hearth or under the fireplace behind the control access panel.
- **MAKE SURE THAT WHERE THE RECEIVER IS PLACED DOES NOT EXCEED 170°F. IT WILL CAUSE DAMAGE TO THE PRODUCT.**
- Use the wires attached to the remote receiver to connect to the gas valve or the electric module.
- Be sure that the connectors do not touch each other or other bare metal surfaces; this will cause the appliance to turn on. The connectors may be wrapped with electrical tape to prevent this.

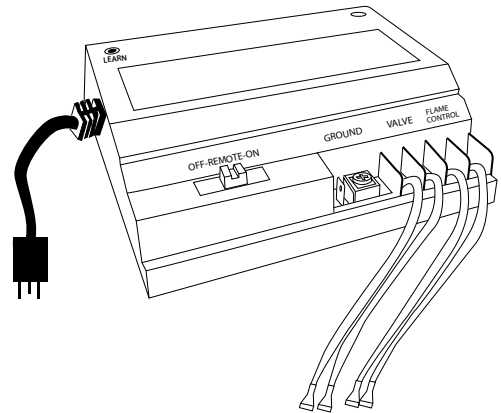

**WIRING INSTRUCTIONS** A qualified electrician should install the remote control system.

#### WIRING MILLIVOLT VALVES

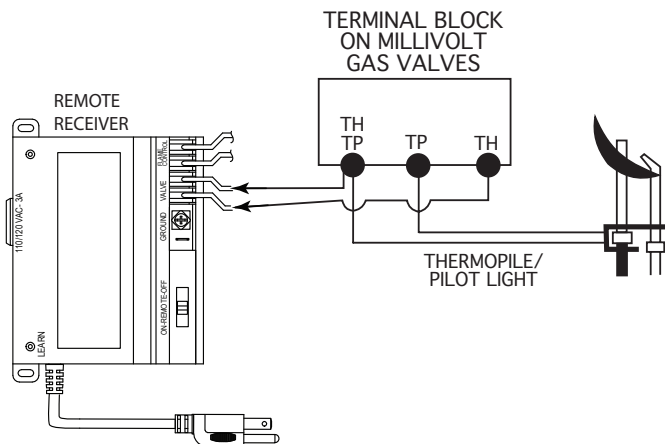

- Connect one wire from the remote receiver's "valve" connection to the TH terminal on the gas valve.
- Connect the other wire from the remote receiver's "valve" connection to the TH/TP terminal on the gas valve.

#### MILLIVOLT SYSTEM CHECK

- Ensure that the pilot flame is lit.
- Slide the 3-position button on the remote receiver to the **ON** position. The main gas flame (i.e., the fire) should ignite.
- Slide the button to **OFF**. The main flame should extinguish (the pilot flame will remain on).
- Slide the button to **REMOTE**, then press the **ON** button on the transmitter to change the system to on. The main gas flame should ignite.

#### WIRING ELECTRONIC SPARK IGNITIONS

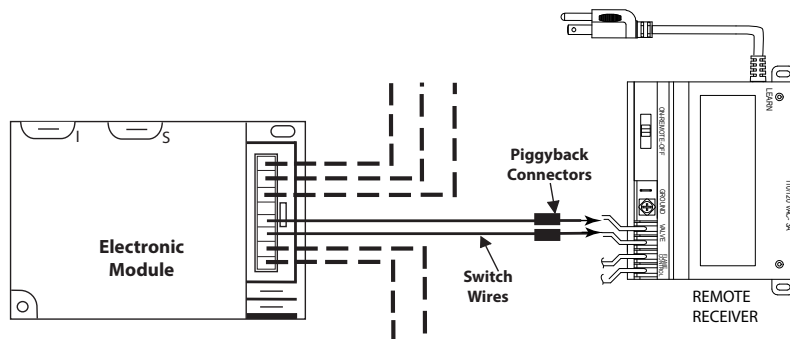

Take both switch/thermostatic wires from the Electronic Module, and connect them to the valve wires using the spade connectors on the receiver.

**NOTE: An adapter may be necessary to make the connection between the Electronic Module and the Remote Receiver.**

## ELECTRONIC SPARK SYSTEM CHECK

- Slide the 3-position button on the remote receiver to the **ON** position. The spark electrode should begin sparking to ignite the pilot. After the pilot flame is lit, the main gas valve should open and the main gas flame should ignite.
- Slide the button to **OFF**. The main gas flame and pilot flame should both extinguish.
- Slide the button to **REMOTE**, then select "ON" with the mode button on the transmitter to change the system to on. The spark electrode should begin sparking to ignite the pilot. After the pilot is lit, the main gas valve should open and the main gas flame should ignite.

## INSTALLING FLAME CONTROL SOLENOID

**ALL STEPS REQUIRED FOR INSTALLATION OF THE FLAME CONTROLLER MUST BE DONE BY A QUALIFIED GAS SERVICE TECHNICIAN**

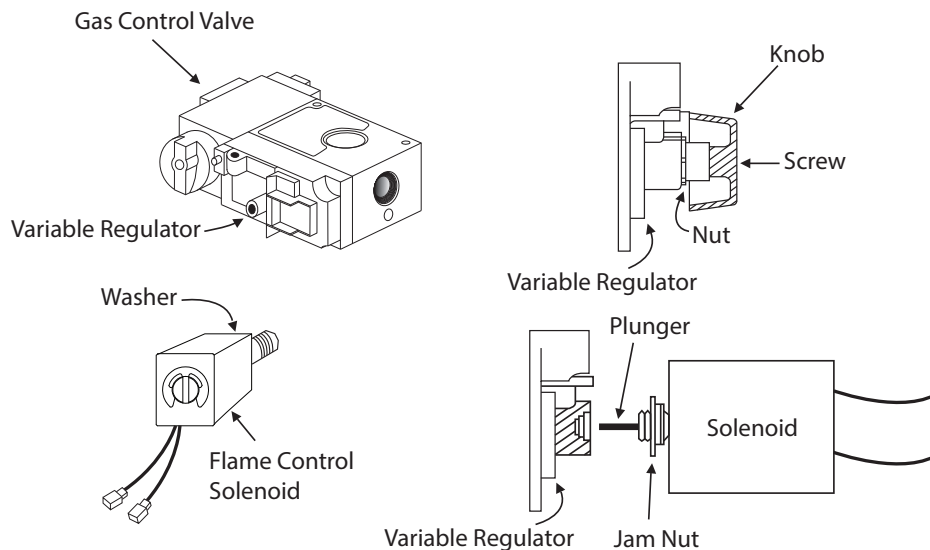

1. Remove the screw and knob from the variable regulator and keep in a safe place.
2. Unscrew the nut from the regulator and keep in a safe place.
3. Remove the bag containing a washer and blue and red plungers from the side of the flame control solenoid.
4. Insert the correct plunger (Blue - natural gas, red - propane) into the flame control solenoid.
5. Thread the flame control solenoid with correct plunger into the thread hole in the variable regulator.

## WIRING SOLENOID TO THE RECEIVER

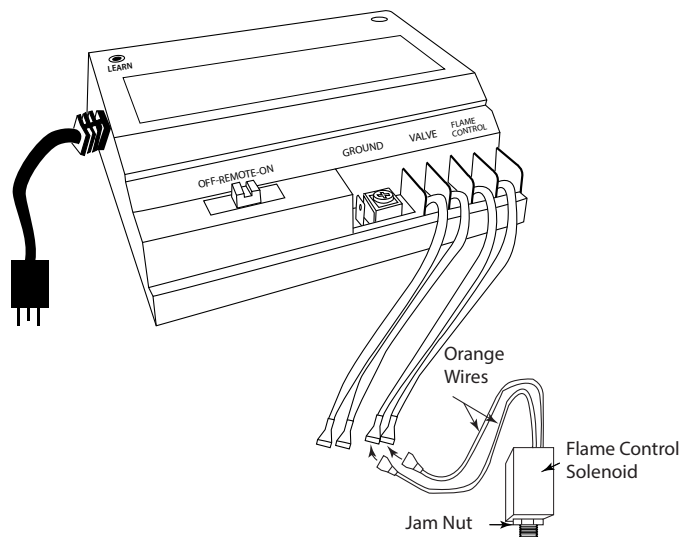

### **CAUTION**

**TO ENSURE SAFE OPERATION, THE OUTLET PRESSURES ON BOTH REGULAR AND HI FLAME LEVELS SHOULD BE CHECKED WITH A MANOMETER IN ACCORDANCE WITH SPECIFICATIONS SUPPLIED BY THE VALVE MANUFACTURER.**

1. Connect the two leads from the flame control solenoid to the orange leads from the receiver.
2. Plug the remote receiver into the 110/120 VAC power supply.
3. Light the fireplace.
4. Tighten the jam nut to the face of the variable regulator body
5. Turn the main gas knob on the gas valve OFF.

## **COMMUNICATION - SAFETY - TRANSMITTER - (C/S - T/X)**

This remote control has a COMMUNICATION –SAFETY function built into its software to ensure the transmitter and receiver are communicating normally.

In all operating modes, the transmitter sends an RF (radio frequency) signal every fifteen minutes to the receiver indicating that the transmitter is within the normal operating range of 20 feet. Should the receiver NOT receive this signal, the receiver will begin a 2 hour countdown. If the receiver does not receive a signal from the transmitter in 2 hours, the receiver will shut off the appliance. The receiver will then emit a series of rapid “beeps” for a period of 10 seconds. Then after 10 seconds of rapid beeping, the receiver will continue to emit a single “beep” every 2 seconds until a transmitter **MODE** Button is pressed to reset the receiver.

## **AUTO SHUT DOWN**

This remote control has an auto shut down feature incorporated into its system. When the transmitter mode is in the ON position, the appliance will only run for 9 hours. After that it will shut down. To reactivate the appliance, press the **MODE** button.

## **CP (CHILDPROOF) FEATURE**

This remote control includes a childproof feature that allows the user to “lock-out” operations from the transmitter.

- To activate and de-activate the childproof feature, press and hold the **SETTING** button behind the battery cover, for 5 seconds (SEE The letters “CP” will briefly appear on the LCD screen when childproof mode is activated).
- “CP” will appear on the LCD screen if any button is pressed while childproof mode is engaged.
- When this mode is engaged, all auto settings go on without interruption (like thermostat). Only manual functions are prevented.

## **TRANSMITTER WALL BRACKET**

The transmitter can be hung on a wall using the clip provided.

- Wood - Drill 1/8” pilot holes and install with screws provided.
- Plaster/Wallboard - Drill 1/4” holes, tap anchors in with hammer, then install with the screws provided.

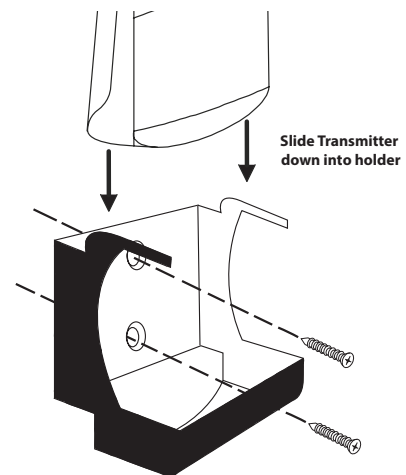

## **BATTERY LIFE**

Life expectancy of the alkaline batteries in the transmitter should be at least 12 months. Check and replace all batteries:

- Annually.
- When operating range becomes reduced.
- When transmissions are not received by the remote receiver.
- If the hand held transmitter batteries measure less than 2.4 volts (Both batteries in combination).

## **LEARNING TRANSMITTER TO RECEIVER**

This transmitter has one of 1,048,576 unique security codes. It may be necessary to program the remote receiver to learn the security code of the transmitter upon initial use, if batteries are replaced, or if using a replacement transmitter.

- Make sure the receiver’s slide switch is in the **REMOTE** position.
- Press and release the **LEARN** button on the receiver.
- When you hear the “Beep”, press and hold the **MODE** button for about 2 seconds on the transmitter.
- If you not hear a beep after you press the **LEARN** button, check that the batteries in the receiver are installed correctly and fully charged.
- You will then hear a series of beeps that indicate that your new transmitter has been accepted by the receiver.

## **TROUBLE SHOOTING**

If you encounter problems with your fireplace system, the problem may be with either the fireplace itself or with the remote. Review the fireplace manufacturer's operation manual to make sure all connections are properly made. Then check the operation of the remote in the following manner:

- Make sure all batteries are correctly installed in the transmitter. Also check that the batteries are fully charged.
- Check batteries in transmitter to make sure contacts are touching (+) and (-) ends of battery. Bend metal contacts in for tighter fit.
- Be sure receiver and transmitter are within 20 to 25-foot operating range.
- Keep receiver from temperatures exceeding 170° F.
- If receiver is installed in a tightly enclosed metal surrounding, the operating distance will be shortened.
- Make sure the hand-held transmitter and remote receiver are communicating properly (see LEARNING TRANSMITTER TO RECEIVER section).

### **FCC REQUIREMENTS**

**NOTE: THE MANUFACTURER IS NOT RESPONSIBLE FOR ANY RADIO OR TV INTERFERENCE CAUSED BY UNAUTHORIZED MODIFICATIONS TO THE EQUIPMENT. SUCH MODIFICATIONS COULD VOID USER'S AUTHORITY TO OPERATE THE EQUIPMENT.**

### **FCC Notification**

**Note:** This equipment has been tested and found to comply with limits for a Class B digital device, pursuant to part 15 of the FCC Rules. These limits are designed to provide reasonable protection against harmful interference in a residential installation. This equipment generates, uses and can radiate radio frequency energy and, if not installed and used in accordance with the instructions, may cause harmful interference to radio communications. However, there is no guarantee that inference will not occur in a particular installation. If this equipment does cause harmful interference to radio or television reception, which can be determined by turning the equipment off and on, the user is encouraged to try to correct the interference by one or more of the following measures:

- Reorient or relocate the receiving antenna
- Increase the separation between the equipment and the receiver
- Connect the equipment into an outlet on a circuit different from that to which the receiver is connected
- Consult the dealer or an experience radio/TV technician for help

**FOR TECHNICAL SERVICE, CALL:**

**Skytech**  
9230 Conservation Way  
Fort Wayne, IN 46809  
(855) 498-8324  
Fax (888) 431-0585

For Sales: (888) 672-8929  
**WEB SITE:** [www.skytechpg.com](http://www.skytechpg.com)



## LIMITED WARRANTY

1. **Limited Warranty.** Skytech II, Inc. ("Skytech") warrants that each new Skytech Control System, including all hardware, parts and components (the "System"), when used in accordance with the instructions furnished by Skytech provided with each System, shall be free in all material respects, of defects in materials and any workmanship under normal use, subject to proper installation ("Limited Warranty"). This Limited Warranty is non-transferrable and sets forth our sole and exclusive liability and the sole and exclusive remedies available in relationship to any non-conformity, defect or similar claim. This Limited Warranty only extends to the original retail purchaser of the System (the "Customer") and expires upon any sale or transfer of the home where the System is installed by the Customer.
2. **System Sold As Is.** Subject to this Warranty and any applicable state law, each System is sold by Skytech to a Customer on an "as is" basis. In addition, each System and Skytech's obligations are and remain subject to all additional disclaimers, limitations, reservations of rights, exclusions, and qualifications set forth on Skytech's website, [www.skytechpg.com](http://www.skytechpg.com), all of which are considered part of the Warranty and are incorporated herein (collectively, the "Additional Terms"). Each Customer, by purchasing and/or using any System or any portion thereof, does so subject to the Warranty and the Additional Terms.
3. **Installation and Use of System.** Improper Installation, adjustment, alteration, service, or maintenance can cause property damage, personal injury, or loss of life. Thoroughly read the installation and operating instructions of this Control as well as the appliance it will be used in conjunction with as a system. If applicable, read the maintenance instructions before installing this control. This product is designed for use with an attended hearth appliance or fire feature. Adults must be present when the Control System is operating. DO NOT program or thermostatically set this Control to operate a hearth appliance or fire feature when Adults are not physically present. Furthermore, DO NOT leave the hearth appliance or fire feature burning unattended; it may cause damage or serious injury. If an Adult is going to be away from the hearth appliance or fire feature for any length of time, then the handheld/wall mount, receiver/control module and application should be in the "OFF" position.
4. **Repair or Replacement of System or Parts.** Should any System, or any hardware, components and/or parts contained therein fail due to a defect in workmanship or material provided by Skytech after the purchase of a System by a Customer, Skytech shall repair or, at its option, replace the defective System or part, hardware or component, subject to the Customer's compliance with all terms and conditions contained herein governing service and claims under the Warranty. Skytech shall provide replacement parts at no charge for the first (5) five years of this warranty, and at market cost for the Lifetime of the product to the original Customer. Gas valve and gas valve components will be available at no charge for one (1) year. If Skytech does not have the parts for an individual model, then a comparable replacement System will be provided at no charge within the first (5) five years after purchase, and then at market cost for the Lifetime of that product to the Customer.
5. **Warranty Claims; Skytech Service.** To submit a valid claim under the Warranty (each, a "Valid Claim"), a Customer must comply with the following:
  - a) Obtain a Return Material Authorization ("RMA") number from Skytech by calling (855) 498-8324; and
  - b) Provide written notice to a Skytech or an Authorized Dealer ("Dealer") and provide the Name, House Address, Email Address and Telephone Number of the Customer;
  - c) Describe the System model number and nature of the defect, nonconformity, or other problem with the System;
  - d) Provide such notice within thirty (30) days of discovery of such defect, nonconformity, or problem;
  - e) securely pack and ship the defective Skytech Product to Skytech II, Inc. ATTN: Warranty Department at 9230 Conservation Way, Fort Wayne, IN 46809. Customer assumes all costs and risks associated with transportation to Skytech (i) the RMA number is only valid for thirty (30) days from the date the RMA was issued, (ii) the RMA number should be clearly marked on the outside of each box being returned. Skytech may refuse shipments that DO NOT meet all of the Valid Claim requirements. Skytech is not responsible for any refused shipments or any damage caused due to shipping, whether or not it was a Valid Claim. Skytech shall be responsible for return shipment charges. Compliance with these requirements is a condition to coverage under this Limited Warranty.

Skytech may refuse any shipment(s) that does not meet all of the Valid Claim requirements. Skytech is not responsible for any refused shipments or any damage caused due to shipping, whether or not it was a Valid Claim. Skytech shall be responsible for reasonable return shipment charges for any Skytech System returned whether or not Skytech determines there is no defect with the System, reject for failure of the Customer to submit a Valid Claim, or otherwise determine is not eligible for service under the Warranty.

Upon receipt of a Valid Claim and the properly-returned System, Skytech shall, at its option, either (a) repair the System, at no charge to the Customer, or (b) replace the returned System with a new comparable System, at no charge to the Customer, or (c) provide the Customer with a refund in an amount equal to the price paid by the Customer for the defective System not including any service or labor cost associated with the installation or otherwise. Any System or

hardware, component or part repaired by Skytech hereunder, or any replacement System, hardware, component or part shall be shipped to the Customer by Skytech at Skytech's cost and the Warranty, the Additional Terms, and all other terms and conditions set forth herein shall extend to such repaired or replacement System, hardware, component or part. Skytech shall pay no refund before Skytech from the Customer receives the defective System, hardware, component and/or parts. Any obligation of Skytech under this Section 4 shall be and remain subject to Skytech's right to physically inspect the defective System, hardware, component and/or part returned to Skytech by the Customer. Some States do not allow the exclusion or limitation of incidental and consequential damages or limitation on how long an implied warranty lasts, so the above limitation may not apply to you. This warranty gives you specific rights and you may have other rights, which vary from state, province, or nation. To the extent allowable under any law, the liability of Skytech is limited to the express terms of this warranty, and Skytech expressly disclaims any and all implied warranties, including any warranties of fitness for a particular purpose or merchantability

REV. 2-24-17



Print information and detach at dotted line for return to: Skytech, ATTN WARRANTY DEPT., 9230 Conservation Way, Fort Wayne, IN 46809  
Telephone: (855) 498-8324

**Warranty Information**

Purchase Date: \_\_\_\_\_ Model: \_\_\_\_\_ Date Code: \_\_\_\_\_

Purchased From: \_\_\_\_\_

Customer Name: \_\_\_\_\_ Phone: \_\_\_\_\_

Address: \_\_\_\_\_

Email Address: \_\_\_\_\_

City: \_\_\_\_\_ State/Prov. \_\_\_\_\_ Zip/Postal Code: \_\_\_\_\_

Back of remote Date Code Sample

16	●	1	2	3	4	5	6
17		7	8	9	10	11	12

1-12 is Month remote was produced 15-  
16 is Year remote was produced  
*Sample date code above is 1611*

***Please send a Proof of Purchase (original receipt) copy along with your Warranty form.***